

ROOF REPLACEMENT PROCEDURE

If Homeowner intends to perform roofing work on their property, the following procedure should be followed:

1. Contact the Villa Antigua Home Owner's Association (Association) office to notify the office of the intended start date and to receive the Association's roofing Specifications. **THE ROOF REPLACEMENT MUST BE DONE IN CONFORMANCE TO THE ASSOCIATION'S SPECIFICATIONS. NO MODIFICATIONS OR DEVIATIONS FROM THE SPECIFICATIONS ARE ALLOWED.**
 - A. Sloped Roof: The required roofing material is 50-year Timberline HD Reflector Series fiberglass shingles, color may be Aged Chestnut, Hickory, Stone Gray or Sandalwood.
 - 1) The architect recommends gutters below all eaves that drain onto the flat roof so that the gravel will remain in place at the end of all sloped roofs.
 - B. Flat Roof: The required roofing material is Johns Manville APPeX 4.5M CR G.
 - 1) The architect recommends that the flat roofs, if not already replaced, on the Corsica (C1 and C2) and Bahia (D1 and D2) models be replaced at the same time as the sloped roof to insure a waterproof transition between the two roofs.
2. Get estimates based on Association's Specifications.
 - C. Select licensed Contractor.
 - D. Insurance: Contractor shall provide proof of insurance and liability and workers' coverage with a Certificate of Insurance showing Workers' Compensation and General Liability coverage.
 - 1) Contractor shall list the Homeowner and the Association as additionally insured. A copy of the insurance certificate must be submitted to Association office prior to start date.
 - 2) Minimum General Liability Insurance Coverage: \$1,000,000 per occurrence.
3. Get samples from Contractor for color selection and to verify conformance with Association's Specifications.
4. Hire Contractor. Contract with Contractor should include:
 - A. **THE ASSOCIATION'S SPECIFICATIONS ARE TO BE PART OF THE CONTRACT!**
 - B. If your Contractor requires a deposit it should be no more than 10% of the contract and not exceed \$1,000.
5. Prior to commencing work:
 - A. Submit a completed Architectural Request for Change (ARC) Form to the Association Office.
 - i. Include a copy of the Contractor's insurance certificate submitted with ARC Form.
 - ii. Be sure to indicate selected shingle color and estimated project start date on the ARC Form.
6. After completion of the work:
 - A. Get lien releases for material and labor and a final, unconditional release from Contractor.
 - B. Ensure Contractor removes all construction debris. A magnet should be used around perimeter of work area to ensure no roofing nails are left behind.
 - C. Contractor to provide copies of Warranty, information about all products used, and manuals for product care and maintenance information.

ROOFING NOTIFICATION FORM

WHEN A HOME IS TO BE REROOFED, HOMEOWNER MUST PROVIDE THE FOLLOWING INFORMATION TO THE ASSOCIATION OFFICE:

HOMEOWNER NAME :

ADDRESS / UNIT NUMBER:

REROOFING CONTRACTOR:

CONTRACTOR'S LICENSE NO:

ESTIMATED START DATE:

ESTIMATED COMPLETION DATE:

COLOR OF SHINGLES (GAF Timberline HD): () Aged Chestnut () Hickory () Sandalwood
() Stone Gray

COLOR OF GUTTERS, FLASHING AND WOOD TRIM:

State Color Scheme #: Stucco color: Trim color: Hardie Color Match:

FLAT ROOF WORK INCLUDED IN SCOPE OF WORK? () YES () NO

THE FOLLOWING ITEMS TO BE ATTACHED:

1. A completed Architectural Request for Charge Form (ARC) Application.
2. A Certificate of Insurance showing Worker's Compensation and General Liability coverage listing homeowner and Villa Antigua Homeowners Association (Association) as additionally insured.

Homeowner agrees to adhere to Association's Roof Replacement Procedure and Roof Replacement Specifications established by Villa Antigua Homeowners Association. Contractor and Homeowner assume all responsibility and liability for any damage done to exterior of homes including decks, windows, all exterior surfaces, and all properties belonging to Villa Antigua Homeowners Association.

Homeowner's Signature: _____ Date: _____

ROOF REPLACEMENT SPECIFICATIONS

SLOPED ROOF SPECIFICATIONS

UNIT TYPE: ALMAR (A1 AND A2), BISCAY (AA1 AND AA2), MALAGA (B1 AND B2), CORSICA (C1 AND C2), BAHIA (D1 AND D2).

1. All work shall comply with the version of the California Building Standards Code currently adopted by the City of San Diego at the time of start of the roofing project.
2. Contractor shall, at all times, keep the job site free from the accumulation of waste material or rubbish caused by Contractor. At the completion of the work, Contractor shall remove all rubbish, tools, construction equipment and surplus materials from the job site and leave the premises in a clean condition to the satisfaction of the Homeowner.
3. Contractor shall use 1/2" CDX plywood panels for roof sheathing.
4. Roofing material shall be GAF Timberline HD shingles Class A, 50-year fiberglass shingles, flashing and all other materials required to re-roof the existing pitched roofs according to manufacturer's specifications.
 - A. All schemes have the option of choosing one of the following Shingle colors:
 - 1) For Aged Chestnut shingles
 - 2) For Hickory shingles
 - 3) For Sandalwood shingles
 - 4) For Stone Gray shingles
5. Underlayment: Contractor shall install GAF Tiger Paw underlayment per manufacturer's instructions.
6. Ridge material shall be GAF Ridglass.
 - A. If Homeowner elects to install ridge vents, install GAF Cobra Exhaust vents.
7. Flashings, counter flashings, drip edges, and roof accessories shall be painted to match HOA approved exterior color scheme, stucco, trim or Hardie. Gutters to be painted to match adjacent surface. Paint all roof metals to match roofing material.
8. Repair and paint new stucco to match color and texture of adjacent existing stucco.
 - A. The stucco is painted La Habra 20-30 mix, medium sand.
9. Roof Penetrations and Accessories: Provide and install new galvanized sheet metal roof jacks and exhaust flue caps to replace those removed in the areas of the work.
 - A. Seal neck with one layer of roof mastic, one layer of fiberglass mesh and a finish layer of mastic.
10. Drip Edge: Provide and install 2" x 3" 26-gauge galvanized sheet metal at all eave and rake conditions in areas of required work per Details 1A and 1B (attached).
 - A. Drip edge shall be continuously nailed along lower edges of high slopes and edge of low slopes. Rake edges of high slopes shall also be continuously nailed.
11. Flashing: Provide and install 26-gauge galvanized sheet metal shingle flashing up and under existing "Z" flashing at all vertical sides of chimney and walls parallel with roof slope.
12. Gutters: If installed, gutters shall be galvanized sectional or extruded aluminum and painted to match adjacent surface.

13. Contractor is responsible for protecting the work from damage caused by water or wind during the course of the project.

ROOF REPLACEMENT SPECIFICATIONS

FLAT ROOF SPECIFICATIONS

UNIT TYPE: ALMAR (A1 AND A2), BISCAY (AA1 AND AA2), MALAGA (B1 AND B2), CORSICA (C1 AND C2), BAHIA (D1 AND D2).

1. All work shall comply with the California Building Standards Code currently adopted by the City of San Diego at the time of start of the roofing project.
2. Contractor shall at all times keep the job site free from the accumulation of waste material or rubbish caused by Contractor. At the completion of the work, Contractor shall remove all rubbish, tools, construction equipment and surplus materials from the job site and leave the premises in a clean condition to the satisfaction of the Homeowner.
3. Flat roofing material shall be a 20-year warranty torch-down modified bitumen roof system: Johns Manville APPeX 4.5M CR Gm with compatible underlayment and flashing.
4. Flashings, counter flashings, drip edges, and roof accessories shall be painted to match HOA approved exterior color scheme, stucco, trim or Hardie. Gutters to be painted to match adjacent surface. Paint all roof metals to match roofing material.
5. Repair and paint new stucco to match color and texture of adjacent existing stucco.
 - A. The stucco is painted La Habra 20-30 mix, medium sand.
6. Roof Penetrations and Accessories: Provide and install new galvanized sheet metal roof jacks and exhaust flue caps to replace those removed in the areas of the work.
7. Contractor shall install new deck drains on all overflow drain systems on all Bahia model units in accordance with local building codes.
8. Contractor shall install a galvanized sectional or extruded aluminum gutter system on Malaga at the end of flat roof terminating into new or existing eave gutter. Paint gutters to match adjacent wood trim.
9. Drip Edge: Provide and install 2" x 3" 26-gauge galvanized sheet metal at all eave and rake conditions in areas of required work per Details 1A and 1B (attached).
 - A. Drip edge shall be continuously nailed along lower edges of high slopes and edge of low slopes. Rake edges of high slopes shall also be continuously nailed.
10. Contractor is responsible for protecting the work from damage caused by water or wind during the course of the project.

1A. DRIP EDGE FOR ALL RAKE CONDITIONS

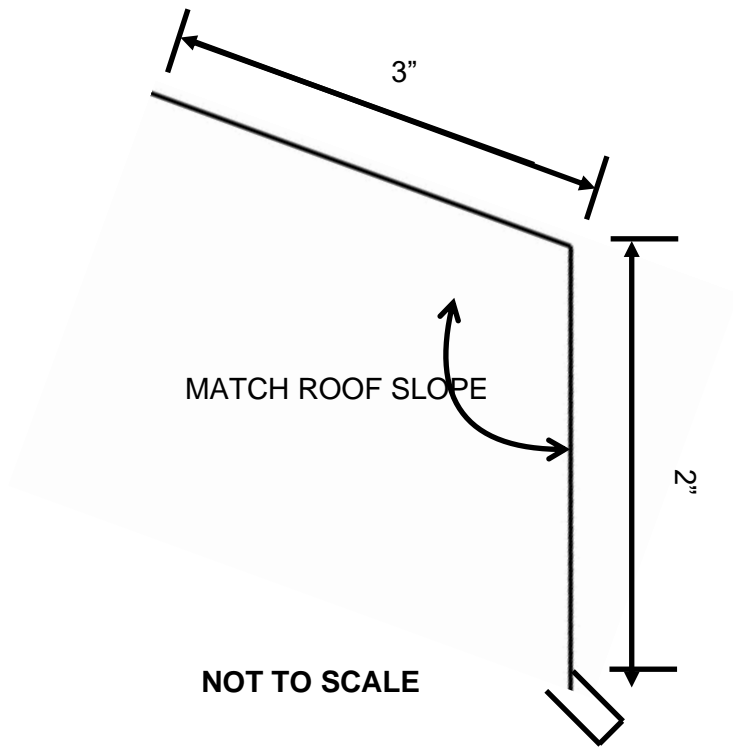

NOTE: METAL EDGE MUST BE HEMMED. USE 26 GAUGE GALVANIZED METAL TO BE PRIMED AND PAINTED.

1B. DRIP EDGE FOR ALL EAVE CONDITIONS

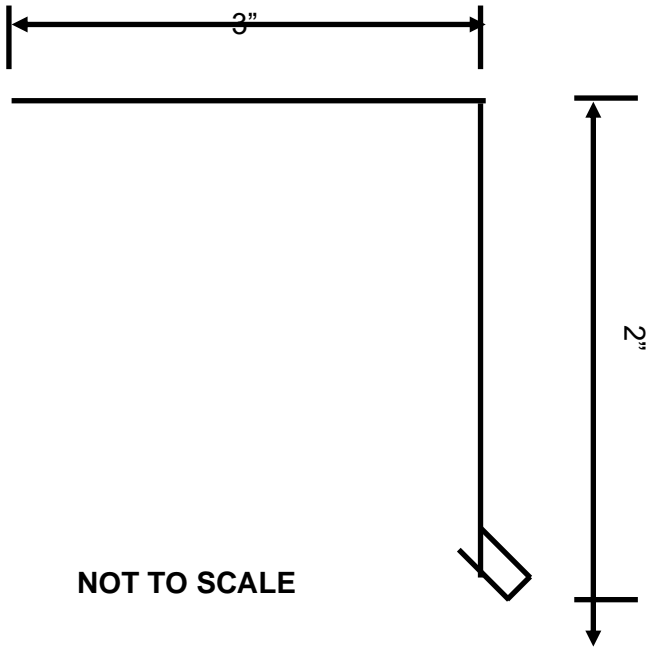

NOTE: METAL EDGE MUST BE HEMMED. USE 26 GAUGE GALVANIZED METAL TO BE PRIMED AND PAINTED.